



STONEX® X200<sup>GO</sup> / X120<sup>GO</sup>

*SLAM Laser Scanner*

**User Guide**



## Contents

Changelog .....	3
1. Legal Notice .....	4
1.1 Copyrights and trademarks .....	4
2. Introduction.....	4
2.1 General .....	4
2.2 Description of the system .....	5
2.3 Precaution for safety .....	6
2.4 Transport and shipping .....	6
2.5 Storage .....	7
2.6 Cleaning and drying .....	7
2.7 Definition of indication.....	7
2.8 Safety standards for lasers.....	8
2.9 Device power supply .....	8
2.10 About User.....	11
2.11 Exceptions from Responsibility.....	11
3. Setting up the STONEX® X200 <sup>GO</sup> / X120 <sup>GO</sup> .....	12
3.1 Device assembly.....	12
3.2 Led status.....	17
3.3 Charging method.....	20
3.4 Data storage .....	20
4. Operating the STONEX® X200 <sup>GO</sup> / X120 <sup>GO</sup> .....	21
4.1 How to use X200 <sup>GO</sup> / X120 <sup>GO</sup> without application .....	21
4.2 How to use X200 <sup>GO</sup> / X120 <sup>GO</sup> with application: <i>GOapp</i> installation .....	21
4.3 Device binding .....	21
4.4 Equipment work .....	24
4.5 Settings .....	28
4.6 Firmware .....	31
5. Data collection .....	34
5.1 Data collections instructions.....	35
5.2 X-Whizz collection.....	38
5.3 RTK data acquisition .....	39
5.4 Drone data collection.....	40

5.5	Data Processing.....	41
6.	Radio kit.....	42
7.	Software license activation request.....	42
8.	Technical data.....	44
8.1	Bundle components.....	44
9.	Appendix.....	44
9.1	X200 <sup>GO</sup> technical features.....	44
9.2	X120 <sup>GO</sup> technical features.....	46

## Changelog

GOapp	
<b>Version 2.9.4 -2.10.13</b>	<ul style="list-style-type: none"> <li>• Support to multi-echoes selection for X120GOv2 and X200GO.</li> <li>• Fixed minor bugs.</li> </ul>
<b>Version 2.9.1</b>	<ul style="list-style-type: none"> <li>• Payload mode support for X200<sup>GO</sup></li> <li>• Mountpoint download improvement</li> </ul>
<b>Version 2.8.10</b>	<ul style="list-style-type: none"> <li>• Added Geotag function for X120<sup>GO</sup>.</li> <li>• Support to X200<sup>GO</sup>.</li> <li>• Added languages (Ukraine, Japanese).</li> <li>• Changes of acquisition interface.</li> <li>• Improved preview stability for X120<sup>GO</sup>.</li> </ul>

# 1. Legal Notice

## 1.1 Copyrights and trademarks

STONEX®, the STONEX® logo, and X200<sup>GO</sup>/ X120<sup>GO</sup> are trademarks of STONEX® S.r.l.

STONEX® GO*app*, STONEX® GO*post* are trademarks of STONEX® S.r.l.

All other trademarks are the property of their respective owners.

# 2. Introduction

## 2.1 General

Thank you for purchasing STONEX® X200<sup>GO</sup>/ X120<sup>GO</sup> 3D Laser Scanner.

This manual includes important safety directions and instructions for setting up and using the product.

Please read this manual carefully before using, so that our products can serve you better.

When you begin to use the product, we assume that you are a competent user who has read through and understood the contents of this manual and is fully aware of the necessary dangers, warnings, and cautions.

In the event of any discrepancy between the information contained in this manual and the actual, the actual information shall prevail, and the Company reserves the right to make further revisions or changes to this manual without notice.

X200<sup>GO</sup>/ X120<sup>GO</sup> 3D Laser Scanner provides a simple and quick way to obtain 3D point cloud data of objects, outdoor or indoor, significantly improving work efficiency and speed.

Laser scanning is an automatic process during which real objects are surveyed and sampled almost completely to determine their location, size, orientation, and shape.

## 2.2 Description of the system

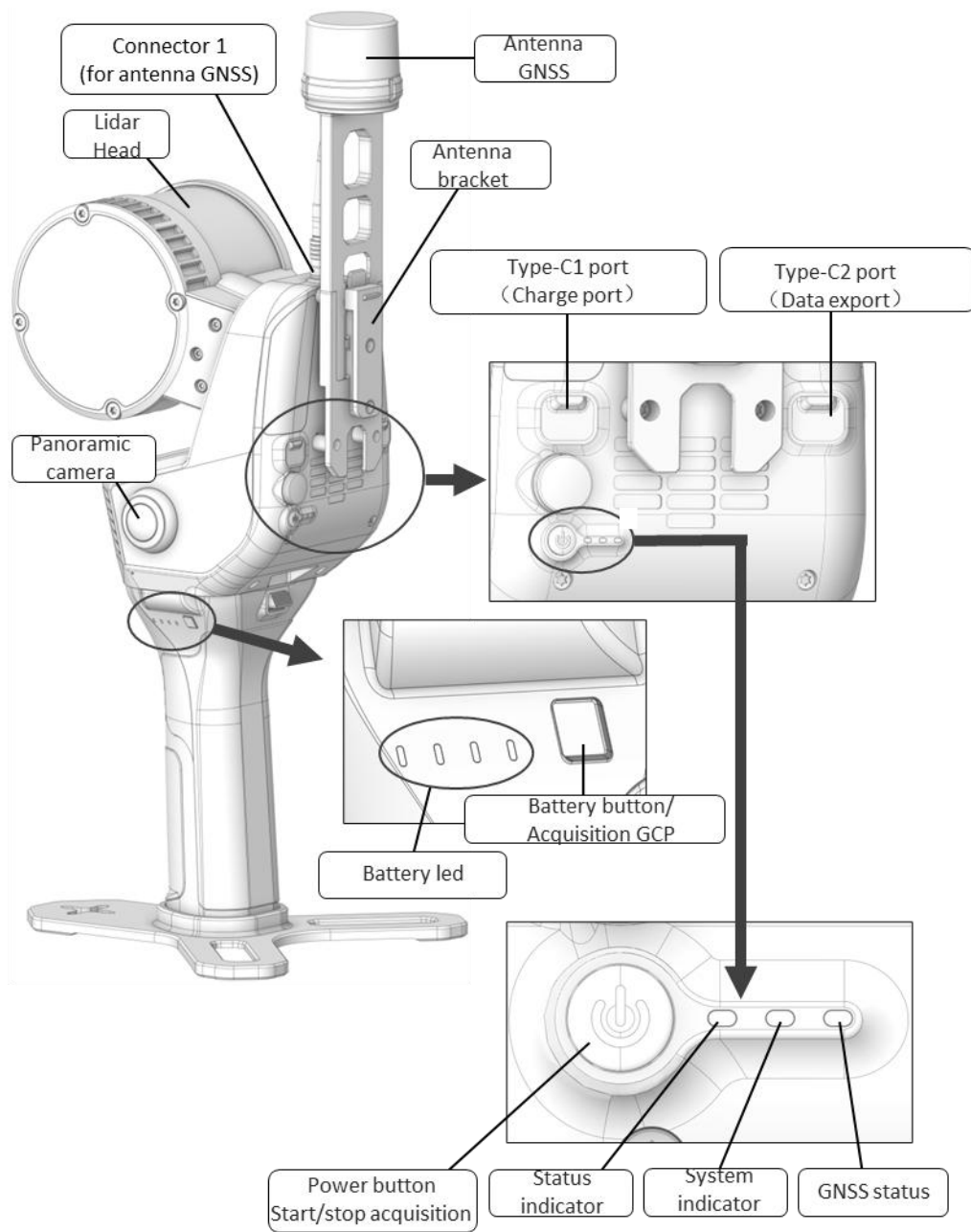

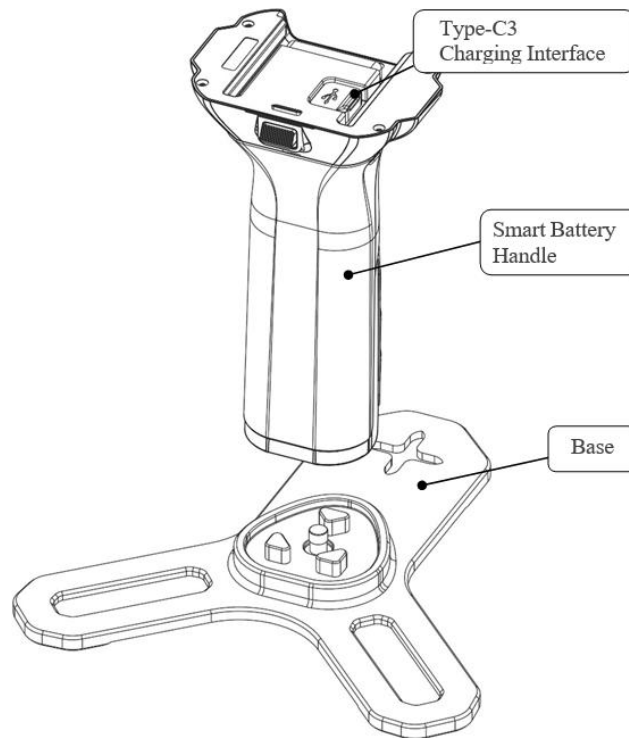

## 2.3 Precaution for safety

1. Avoid vibrations: when transporting, keep the instrument in the case and try your best to lighten vibrations.
2. Instrument carrying: when carrying, the instrument handle must be hold tight.
3. Check the battery power: before using the instrument, you should check the battery power whether it is enough.
4. High temperature condition: don't put the instrument in high temperature condition for a long time, it is bad for the instrument performance, and it can damage the hardware components.
5. Temperature changing sharply: the sharp temperature changing on the instrument will shorten the distance measurement range. For example, after taking the instrument out from a warm car to a cold condition, wait for some time: it can be used when it adapts the surrounding condition.
6. Noise from the instrument: when the instrument is working it is normal if you hear noises from instrument motors. They will not affect the instrument work.
7. Stored data responsibility: STONEX® should not be held liable for the lost data because of wrong operation.

## 2.4 Transport and shipping

### TRANSPORT IN THE FIELD

1. When transporting the equipment in the field, always make sure that you:
  - a. either carry the product in its original transport container,
  - b. or carry the tripod with its legs splayed across your shoulder, keeping the attached product upright.

### TRANSPORT IN A ROAD VEHICLE

2. Never carry the product loose in a road vehicle, as it can be affected by shock and vibration.

3. Always carry the product in its transport container and secure it.

## SHIPPING

4. When transporting the product by rail, air, or sea, always use the complete original STONEX® packaging, transport container and cardboard box or its equivalent to protect the instrument against shock and vibration.

## SHIPPING AND TRANSPORT OF BATTERIES

5. When transporting or shipping batteries, the person in charge of the product must ensure that the applicable national and international rules and regulations are observed.
6. Before transportation or shipping, contact your local passenger or freight transport company.

## FIELD ADJUSTMENT

7. After transport, inspect the field adjustment parameters given in this user manual before using the product.

## 2.5 Storage

1. Keep away from magnetic fields.
2. Protect against falling.
3. Prevent crushing.
4. Keep away from humid environments.

If the device is not used for a long time, please store it in a safe, dry and ventilated place that avoids direct sunlight, the storage environment requires a relative humidity of less than 200%, and a temperature between -20°C and +60°C to avoid excessive humidity in the environment that causes the device to produce condensation. The recommended storage temperature is +5°C ~ +28°C.

## 2.6 Cleaning and drying

- Never touch the cover glass with your fingers.
- Use only a clean, soft, lint-free cloth for cleaning.
- If necessary, moisten the cloth with water or pure alcohol. Do not use other liquids.
- Keep plugs clean and dry. Blow away any dirt lodged in the plugs of the connecting cables.

## 2.7 Definition of indication

For the safe of your product and prevention of injury to operators and other persons as well as prevention of property damage, items which should be observed are indicated by an exclamation point within a triangle used with WARNING and CAUTION statements in this manual.

The definitions of the indications are listed below.

Be sure you understand them before reading the manual's main text.



ATTENTION:

Ignoring this indication and making an operation error could possibly result in death or serious injury to the operator.



**CAUTION:**

Ignoring this indication and making an operation error could possibly result in personal injury or property damage.



**ATTENTION**

1. Do not perform disassembly or rebuilding. Fire, electric shock, or burn could result. Only STONEX® authorized distributors can disassemble or rebuilt.
2. Do not cover the charger. Fire could result.
3. Do not use deflection power cable, socket, or plug. Fire, electronic shock could result.
4. Do not use wet battery or charger. Fire, electronic shock could result.
5. Do not close the instrument to burning gas or liquid, and do not use the instrument in coal mine. Blast could result.
6. Do not put the battery in the fire or high temperature condition. Explosion, damage could result.
7. Do not use the power cable which is not specified by STONEX®. Fire could result.
8. When this product encounters disturbance of severe Electrostatic Discharge, perhaps it will have some degradation of performance like switching on/off automatically and so on.



**CAUTION**

1. Do not touch the instrument with wet hand. Electric shock could result.
2. Do not stand or seat on the carrying case, and do not turn over the carrying case arbitrarily, the instrument could be damaged.
3. Do not drop the instrument or the carrying case.
4. Do not touch liquid leaking from the instrument or battery. Harmful chemicals could cause burn or blisters.
5. Do not drop the instrument. Serious damage could result.
6. Please be careful when removing the scanner from the equipment case and take care to protect the laser head.
7. Do not touch the protective cover of the laser emitting area with your hands.
8. Please try to keep the scanner moving smoothly during data collection and avoid violent shaking.

## 2.8 Safety standards for lasers

STONEX® X200<sup>GO</sup>/ X120<sup>GO</sup> series adopt the class of Laser Product according to IEC Standard Publication 60825-1:2014. According to this standard, the device is classified as Class 1 Laser Product.

## 2.9 Device power supply

X200<sup>GO</sup>/ X120<sup>GO</sup> scanner handle integrate 3000mAh replaceable lithium battery, safer and more reliable. Working voltage 10.8V, each battery single continuous working time of about 100 min (separate power supply X200<sup>GO</sup>/ X120<sup>GO</sup>). The battery in normal maintenance under normal use conditions, charge and discharge cycle times ≥ 500

times.

### Charging advice

1. Do not use non-standard power adapter to charge the battery.
2. If the temperature of the battery is high after the operation, it is necessary to wait until the battery is reduced to room temperature before charging the battery, and the ambient temperature of battery charging is required to be within the range of 5°C to 200°C.
3. Please charge in the isolated area, away from flammable materials. To avoid the danger of electric shock, please do not open the charger without authorization.
4. To avoid the danger of electric shock, please do not open the charger without authorization.

### Operation advice

1. Battery use temperature is required to be controlled at -10°C ~+50°C, if the battery temperature is too low, it will affect the lithium-ion activity and discharge efficiency.
2. Please make sure the device connection port is dry and free of water before connecting and installing.
3. Please keep the Smart Battery Grip out of direct sunlight.
4. Using the battery in a low temperature environment (-10°C~15°C) will reduce the battery capacity and discharge voltage, it is recommended to preheat the battery to 15°C or above before use, and it is better to preheat it to 20°C or above.
5. Do not remove the battery directly from a powered device.
6. Low battery temperature triggers low temperature charging protection and prevents charging.
7. Do not continue to use a battery that has been deformed by a fall or impact.
8. If the battery accidentally falls into water, immediately remove the battery, and place it in a safe, open area, away from the battery until it is completely dry. Air-dried batteries should not be reused and should be disposed of properly according to the disposal instructions in this document.
9. If the battery fire occurs, please use water, water mist, sand, fire blanket, dry powder,
10. carbon dioxide fire extinguisher to extinguish the fire immediately, the fire is very easy to explode. Please choose the fire extinguishing method according to the above recommended order according to the actual situation.
11. It is strictly prohibited to use batteries that are not officially provided by Stonex. If you need to replace the battery, please purchase it from Stonex or Stonex dealers. Stonex is not responsible for battery accidents or equipment failures caused using batteries other than those provided by Stonex.
12. Battery storage temperature and humidity requirements are -20°C ~45°C, 45%~90%RH.
13. It is strictly prohibited to use or charge batteries that are bulging, leaking or damaged. Do not use the battery when it emits a strange odor, becomes hot (the temperature of the battery itself exceeds 60°C), deformed, discolored or any other abnormal phenomenon. If the battery is abnormal, please contact Stonex after-sales service or other agents for further treatment.
14. Use the battery in an environment where the temperature is between -10°C and 50°C. Excessive temperatures (above +50°C) may cause the battery to catch fire or even explode. Too low a temperature (below -10°C) will seriously damage the battery.
15. It is prohibited to disassemble or puncture the battery with sharp objects in any way. Otherwise, battery leakage will cause fire or even explosion.
16. Do not mechanically strike, crush, or throw the battery. Do not place heavy objects on the battery or charger.
17. If the battery is dropped or struck by an external force, stop using the battery.

18. Do not heat the battery. Do not place the battery in a microwave oven or pressure cooker.
19. Do not place battery contacts on a conductive surface (such as a metal tabletop, glasses, watch, jewelry, or other metal objects).
20. Do not short-circuit the positive and negative terminals of the battery with wires or other metal objects.
21. If the battery connector is dirty, wipe it with a clean, dry cloth. Failure to do so will result in poor battery contact, which may cause energy loss or charging malfunction.

### Transportation

Batteries should be placed in a safe box during transportation to avoid contact with liquids or bumping against hard objects, and never immerse them in water or get them wet. When the battery is exposed to water, it may decompose and cause spontaneous combustion or even an explosion.

### Maintenance

After each operation, the battery should be recharged in time, please do not store the low battery for a long time, if not used for a long time, please charge the battery to more than 50% and then store it and carry out charging and discharging maintenance every 3 months.

### Battery storage

1. Please store the battery out of the reach of children and pets.
2. Batteries should be stored in an explosion-proof box in a cool and dry place, prohibited from prolonged exposure to high temperatures and avoid direct sunlight.
3. Do not place the battery near a heat source (furnace or heater, and so on), and do not leave the battery in a car on a hot weather day. Do not store the battery in an environment that exceeds 60°C. The ideal storage temperature is 22°C - 28°C.
4. May not be stored in multiple occurrences of alternating high and low temperature environments.
5. May not be stored in a fully charged transportation box when the battery temperature exceeds 45°C.
6. Prolonged low battery storage will result in over-discharge of the battery, which may even cause the battery to be scrapped in severe cases.
7. Do not place sharp objects with or puncture the batteries.
8. Prevent the battery from being dropped and knocked.
9. Store the battery in a dry environment.
10. Do not store the battery for long periods of time after it has been completely discharged to avoid over-discharging the battery and causing damage that will make it impossible to restore it to service.

### Battery disposal

1. Do not disassemble, impact, extrude the battery or put it into fire. Please do not put the battery in a high temperature environment.
2. If the battery is bulging, broken or leaking, please do not use it again and dispose of it in time.
3. Be sure to discharge the batteries completely before disposing of them in the designated battery recycling bin. Batteries are hazardous chemicals and should not be disposed of in the regular trash. For details, follow your local battery recycling and disposal laws and regulations.
4. If the battery cannot be completely discharged, please do not dispose of the battery directly in the battery recycling bin and contact a professional battery recycling company for further processing.

## Battery specifications

Model	<b>SP30</b>
Charging interface	Type-C3 port
Input voltage	5-20 V
Output voltage	10.8 V
Battery capacity	3000 mAh
Standard	GB31241-2014S
Duration	100 min
Weight	About 2000 g
Dimension	Length×Width×Height 85 mm×60 mm×144.5 mm

## 2.10 About User

1. The X200<sup>GO</sup>/ X120<sup>GO</sup> Scanner must be used by trained operators only. When operating the X200<sup>GO</sup>/ X120<sup>GO</sup>, please always follow basic safety precautions to prevent injury or damage to equipment.
2. The user is required to be a qualified surveyor or have a good knowledge of surveying, in order to understand the user manual and safety instructions, before operating, inspecting, or adjusting.
3. Do not operate the equipment if it shows obvious defects or damage. Please follow STONEX<sup>®</sup> service procedure to repair the equipment.
4. Please use only the components and accessories provided by the manufacturer.
5. Before operating the X200<sup>GO</sup>/ X120<sup>GO</sup> for the first time, please read this manual completely.
6. The equipment contains electrical components and mechanical parts, so proper operation is required. Do not pull or bend the data transmission line forcibly.
7. Do not push any other objects into the data transmission line interface, place the device out of the reach of children, and do not modify or disassemble the X200<sup>GO</sup>/ X120<sup>GO</sup> scanner under any circumstance without the prior written permission of STONEX<sup>®</sup>. Otherwise, the warranty would not be applied.

## 2.11 Exceptions from Responsibility

1. The user of this product is expected to follow all operating instructions and make periodic checks of the product's performance.
2. The manufacturer assumes no responsibility for results of a faulty or intentional usage or misuse including any direct, indirect, consequential damage and loss of profits.
3. The manufacturer assumes no responsibility for consequential damage and loss of profits by any disaster, such as earthquakes, storms, floods etc.
4. The manufacturer assumes no responsibility for any damage and loss of profits, due to a change of data, loss of data, an interruption of business etc., caused by using the product or an unusable product.
5. The manufacturer assumes no responsibility for any damage and loss of profits, caused by usage except for explained in the user manual.
6. The manufacturer assumes no responsibility for damage caused by wrong transport or action, due to

connecting with other products.

### 3. Setting up the STONEX® X200<sup>GO</sup>/ X120<sup>GO</sup>

#### 3.1 Device assembly

##### Mounting base

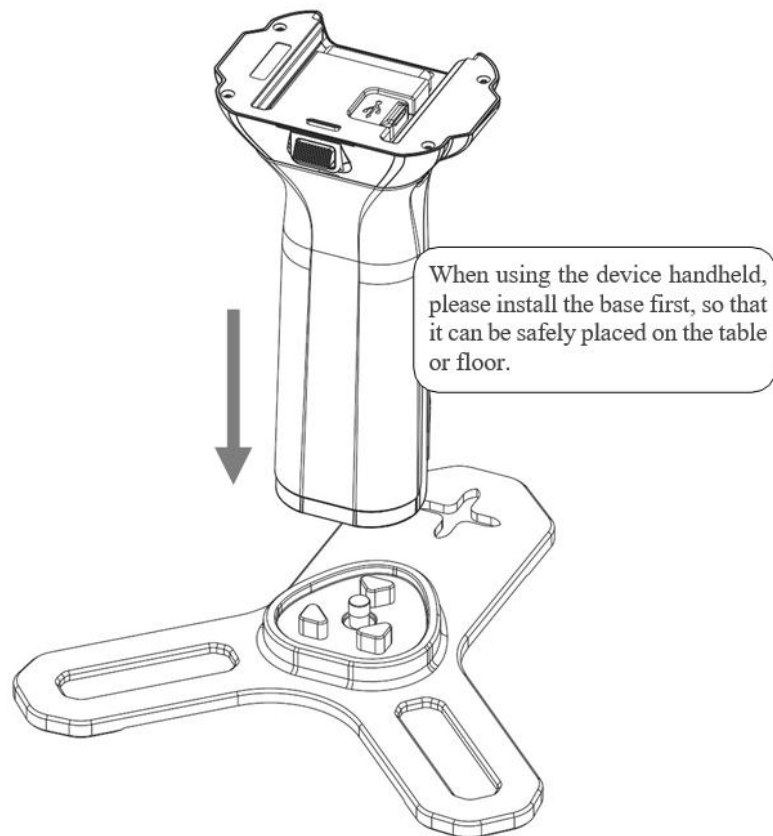

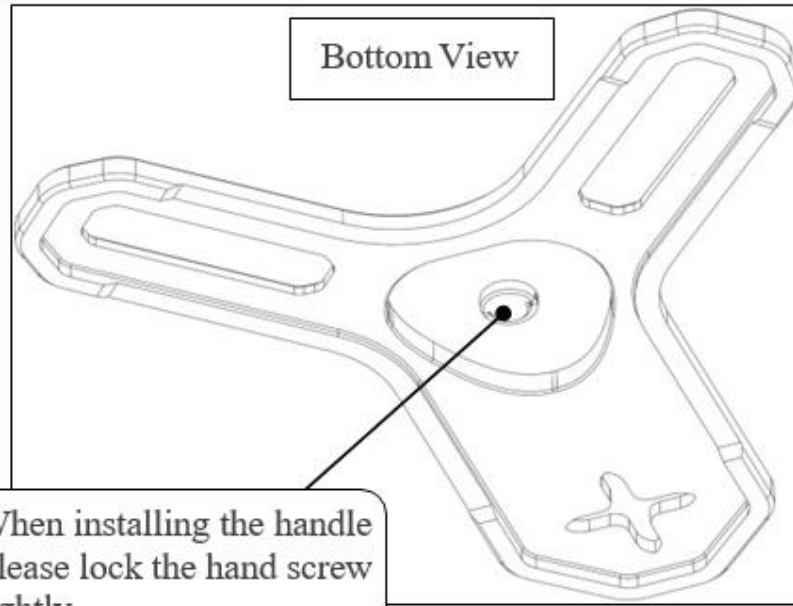

## Assemble handle

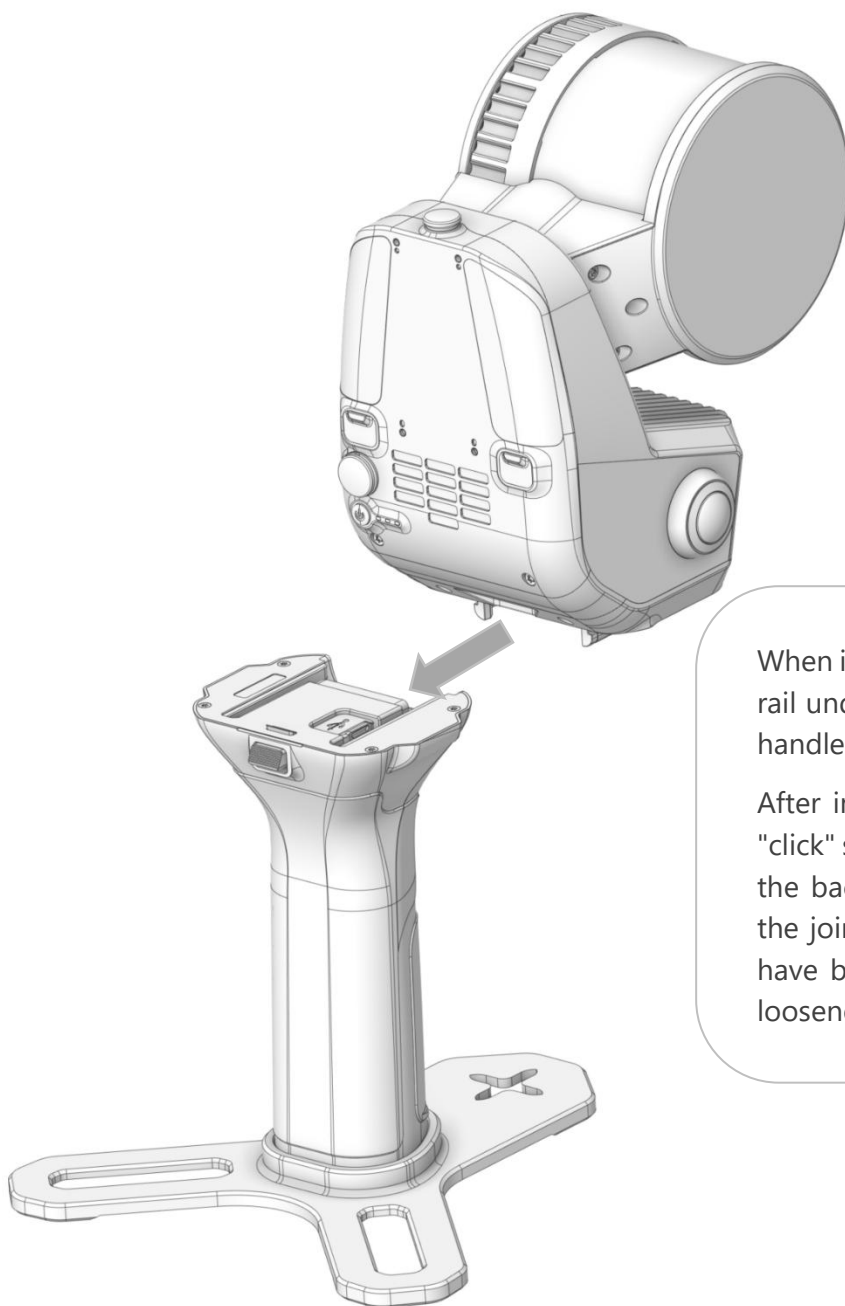

When installing the handle, first align the slide rail under the handle with the slot above the handle and then push it in.

After installing it in place, you can hear the "click" sound. Check that the release button at the back of the handle is fully rebound, and the joints between the body and the handle have been aligned and are solid and free of looseness.

## Detach handle

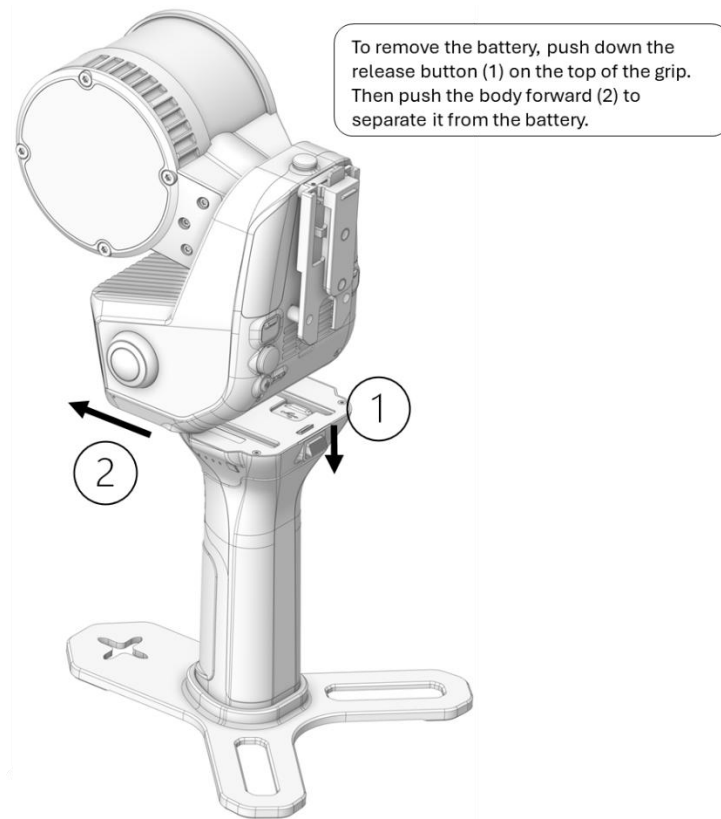

## Mount GNSS receiver

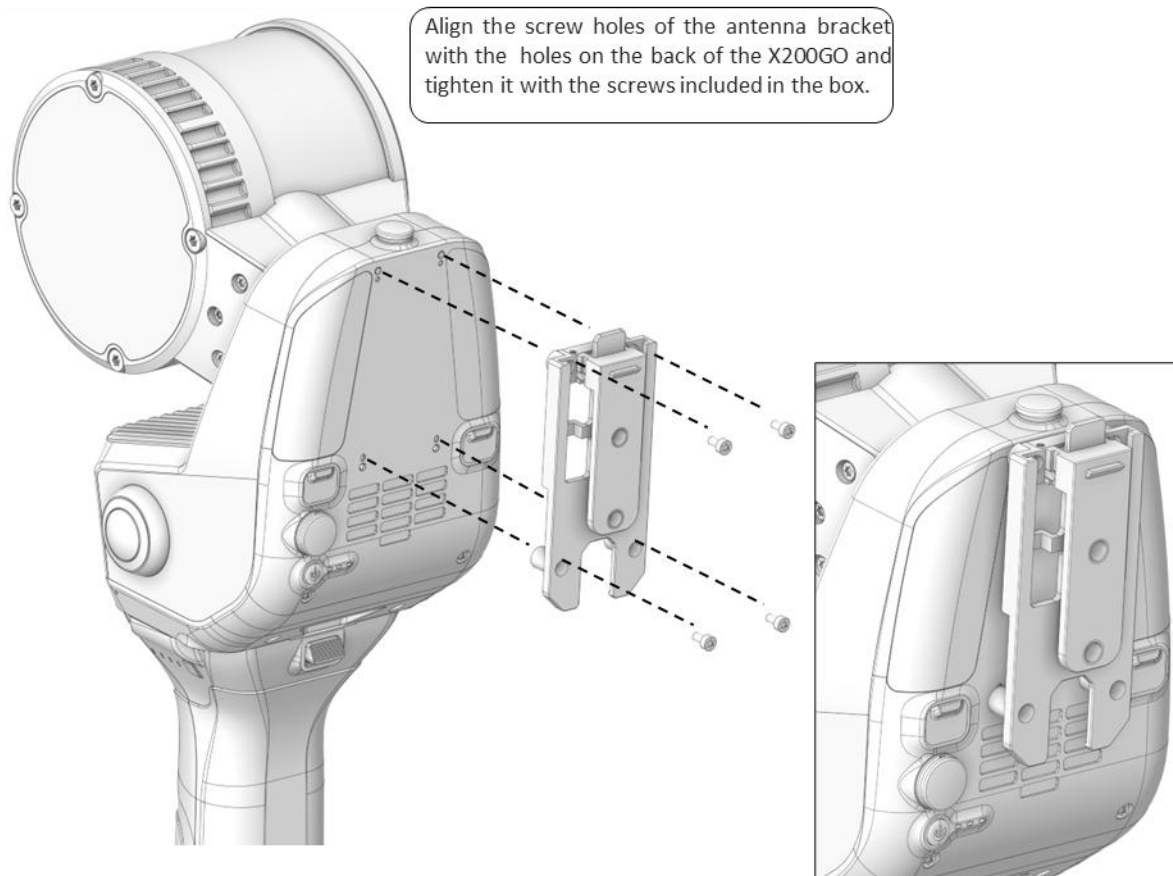

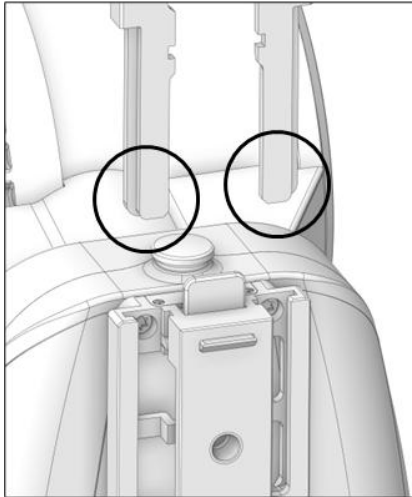

Insert the antenna from top to bottom, after hearing the 'click' sound, check that the antenna assembly and the bracket fit tightly and securely installed.

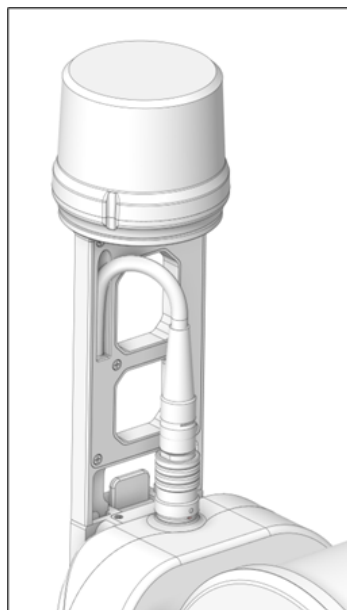
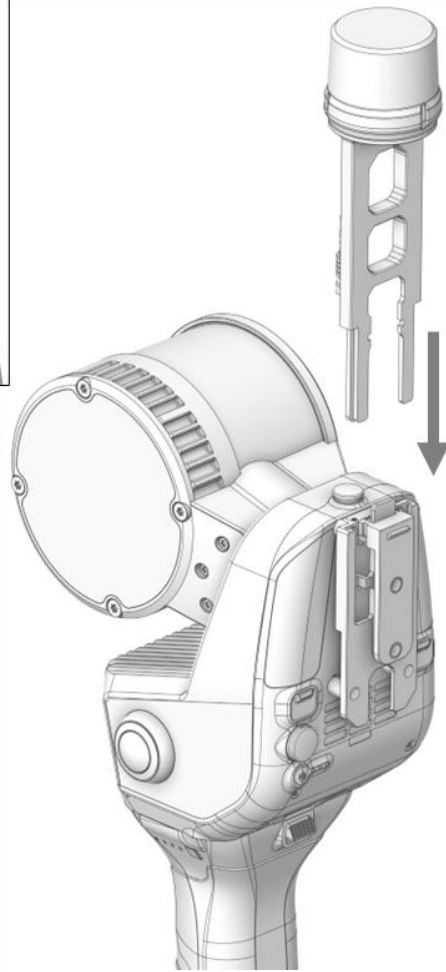

Connect the antenna cable (when not using the RTK function, do not install this component). Check that the red mark is in correspondence with the red mark of the connection port.

Remove the cable from the scanner. To take out the antenna, press the release button on the bracket.

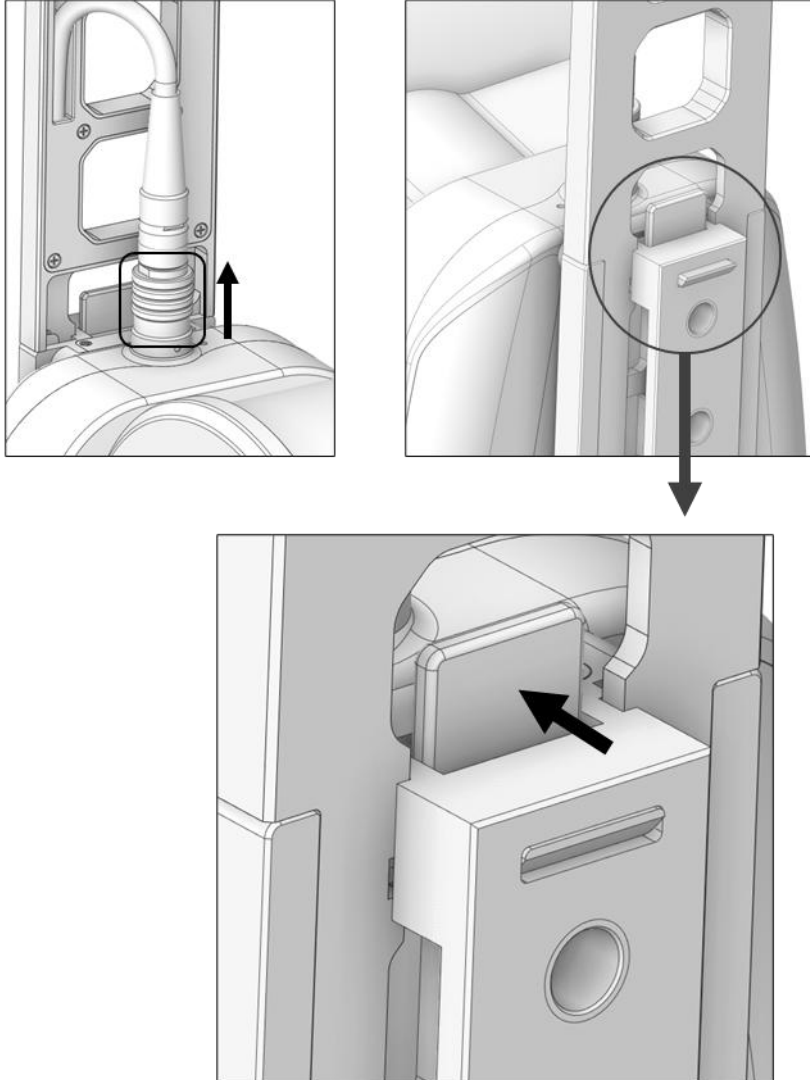

### 3.2 Led status

#### System information

The system will provide visual and audio inputs to the user, in order to understand the status of the system.

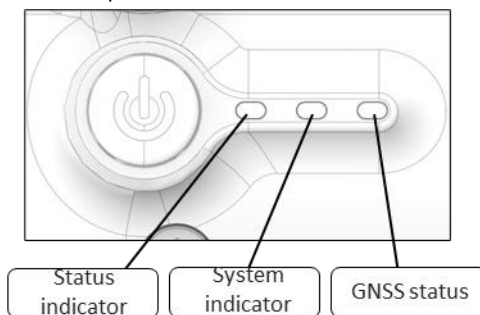

	Led color	Indicator Status
System Indicator	Firmware upgrade	White light, on
	System not ready	Red light, flashing
	System ready	Blue light, on
Status Indicator	MCU Firmware upgrade	White light, flashing fast
	Device initialization	Red light, on
	Device ready	Green light, on
	Data collection in progress	Green light, flashing
GNSS status	No network	Red light, flashing fast
	No positioning	Red light, flashing slow
	Single solution	Red light, always on
	Pseudo-range solution	Blue light, always on
	Float solution	Green light, flashing slow
	Fixed solution	Green light, always on

	Sound	Sound description
Buzzer	One beep	Power ON
	One beep	Shutdown
	One beep every 10 seconds	Low battery
	One beep every second	Ultra-low battery
	One beep	GCP information collection
	One beep	Start data collection

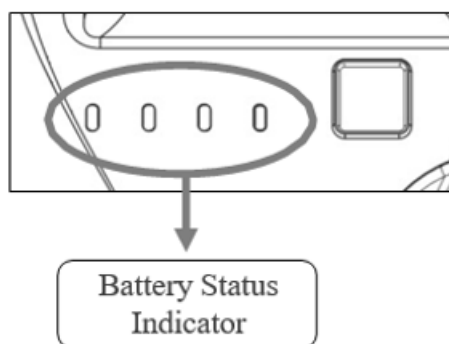

The battery status indicator will show the percentage of the remaining battery. It will also give information about the charging and discharging conditions.

Battery LED Indicator Status List					
Status		LED1	LED2	LED3	LED4
	Undervoltage	Flash(5Hz)	Slow Flash(1Hz)	Out	Out
	Discharge Low	Flash(5Hz)	Out	Slow	Out

Discharge Protection Status	Temperature			Flash(1Hz)	
	Discharge Over Temperature	Flash(5Hz)	Out	Out	Slow Flash(1Hz)
	Discharge Overcurrent	Flash(5Hz)	Slow Flash(1Hz)	Slow Flash(1Hz)	Out
	Discharge Short Circuit	Flash(5Hz)	Slow Flash(1Hz)	Slow Flash(1Hz)	Slow Flash(1Hz)
Charge Protection Status	Overvoltage	Slow Flash(1Hz)	Out	Out	Flash(5Hz)
	Charging Low Temperature	Out	Slow Flash(1Hz)	Out	Flash(5Hz)
	Charging Over Temperature	Out	Out	Slow Flash(1Hz)	Flash(5Hz)
	Charging Overcurrent	Slow Flash(1Hz)	Slow Flash(1Hz)	Out	Flash(5Hz)
Power Indicator	0%~12%	Slow Flash(1Hz)	Out	Out	Out
	13%~24%	Always On	Out	Out	Out
	25%~37%	Always On	Slow Flash(1Hz)	Out	Out
	38%~49%	Always On	Always On	Out	Out
	50%~62%	Always On	Always On	Slow Flash(1Hz)	Out
	63%~74%	Always On	Always On	Always On	Out
	75%~87%	Always On	Always On	Always On	Slow Flash(1Hz)
88%~100%	Always On	Always On	Always On	Always On	

	Status	LED1	LED2	LED3	LED4
Charging Indicator	0%~24%	<b>LED1-&gt;LED4 Streaming LED Display</b>			
	25%~49%	Always On	<b>LED2-&gt;LED4 Streaming LED Display</b>		
	50%~74%	Always On	Always On	<b>LED3-&gt;LED4 Streaming LED Display</b>	
	>=75%	Always On	Always On	Always On	<b>Slow Flash(1Hz)</b>
	Full	Always On	Always On	Always On	Always On

**Description:** The LED will light up for 6 seconds when you press the key to check the power level, the first 3 seconds will show the power level, the last 3 seconds will show the power level if the battery is normal, otherwise it will show the protection status.

### 3.3 Charging method

The X200<sup>GO</sup>/ X120<sup>GO</sup> battery can be charged by connecting the charger to the battery via a Type-C cable.

**Mode 1:** The charger is connected to the Type-C port on the X200<sup>GO</sup>/ X120<sup>GO</sup> grip for charging.

**Mode 2:** When the grip is mounted to the X200<sup>GO</sup>/ X120<sup>GO</sup> body, the charger is connected to the Type-C port on the body for charging.

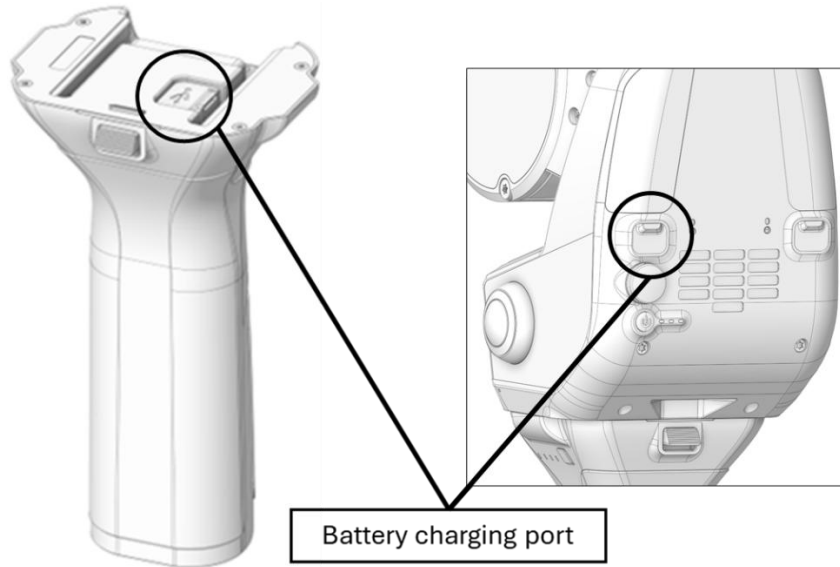

### 3.4 Data storage

X200<sup>GO</sup>/ X120<sup>GO</sup> uses build-in SSD memory with a capacity of 512 GB and can be connected to a PC via a data cable for data interaction.

The SSD interface can be accessed when the scanner is turned off.

When deleting data is recommended to format the memory (fast formatting is possible), so that the SSD disk always performs at maximum storage speed.

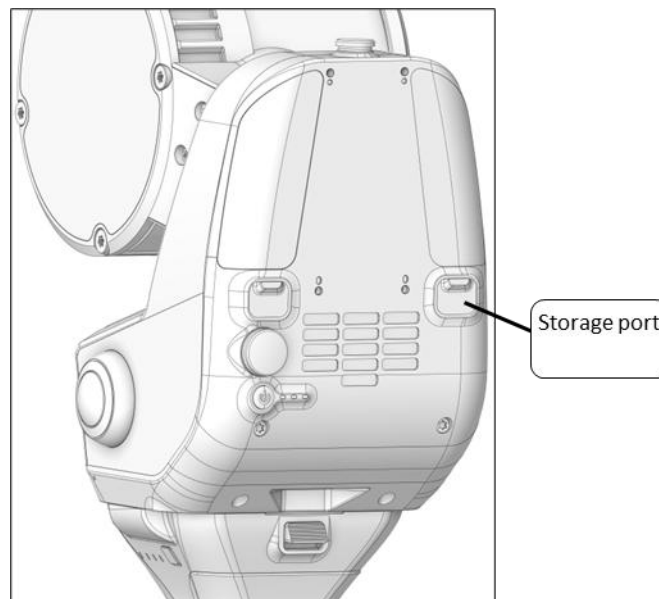

## 4. Operating the STONEX® X200<sup>GO</sup>/ X120<sup>GO</sup>

### 4.1 How to use X200<sup>GO</sup>/ X120<sup>GO</sup> without application

The X200<sup>GO</sup>/ X120<sup>GO</sup> scanner can be used without other devices. For proper use follow the rules below:

- Turn on the scanner by pressing the power button for a couple of seconds.
- Place the scanner in a stable spot for initialisation. Press the power button once, followed by an audible warning. The green LED will start flashing indicating that the instrument is acquiring data correctly.
- Wait one minute for the instrument to initialise. Make sure that there are no people or objects moving in front nearby. After the first minute, the head will start to turn, and a second beep will indicate the start of data acquisition. Pick up the scanner and start scanning.
- If you wish to acquire a control point, place the scanner over a target or recognisable point and stand over this point for a few seconds and press the button on the side of the handle (not the power button) to save the position of the control point.
- To end the scan, press the power button once. The real slam processing will start with a fast blinking of the light. After the led stop flashing, the data are processed and the scanner can be turned off.

### 4.2 How to use X200<sup>GO</sup>/ X120<sup>GO</sup> with application: GOapp installation

GOapp is mobile APP for X200<sup>GO</sup>/ X120<sup>GO</sup> for Android (8.0 version or above) and iOS, which allows to perform operations such as project management, real-time point cloud display, image preview, firmware upgrade, etc.

1. Download the application from your device app store.



2. You can download it also from the app store of your device.

### 4.3 Device binding

The first time you open the GOapp, you will have the following page, where the **Add Now** button allows to bind a new device.

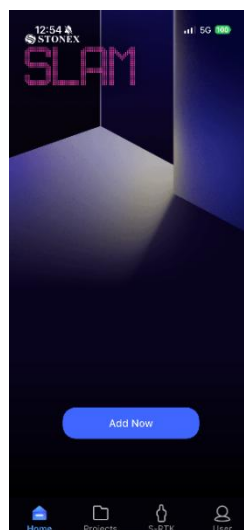

X200<sup>GO</sup>/ X120<sup>GO</sup> should relate to Bluetooth of the tablet on which is installed GOapp.  
Turn first the hot spot and the Bluetooth of the tablet.

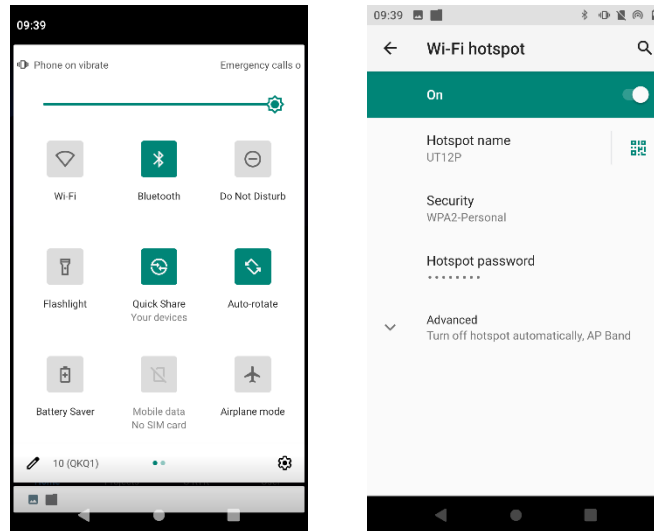

Open the APP homepage, press and hold the power button of X200<sup>GO</sup>/ X120<sup>GO</sup> scanner for 3 seconds, wait for about a minute. Select the symbol of Bluetooth in the app and choose the device by the serial number.

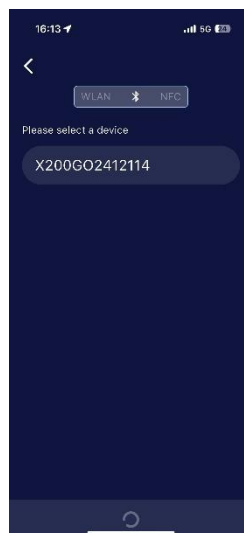

Enter the hot spot name and the password of the tablet and click confirm.  
This way the connection between the tablet and the scanner will be set. Remember to turn on the hot spot before opening the application in order to have the automatic connection between the two devices after the first time.

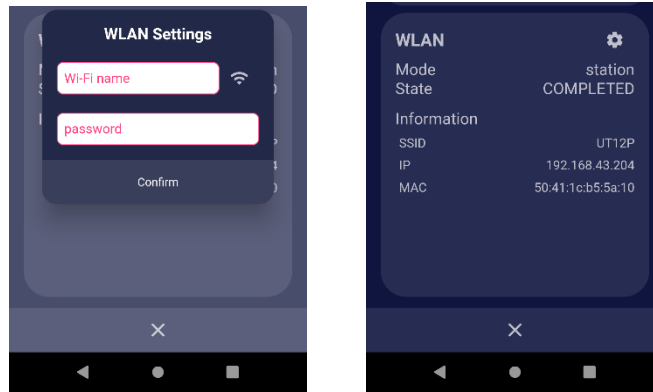

X200<sup>GO</sup>/ X120<sup>GO</sup> scanner equipment will automatically appear on the homepage.

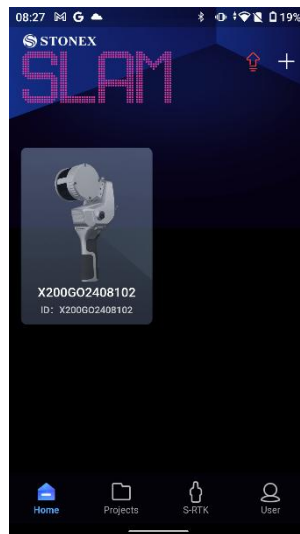

### User settings

By clicking the user icon, the user settings page will open. In this page is possible to change the language, by clicking **Language** (English, Italian, Chinese available now), and is possible to check the installed applications version by clicking **About GOapp**. The **Export Log** should be used only if requested by stonex support team.

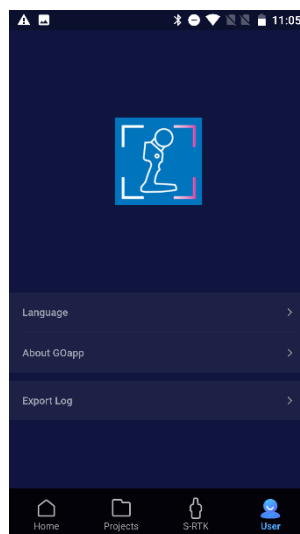

## 4.4 Equipment work

Connect the X200<sup>GO</sup>/ X120<sup>GO</sup> scanner through mobile phone Wi-Fi, click on the online device with the green dot logo in the upper right corner of the APP page.

After successful connection, the equipment will be initialized. Click on **Start work** to start the scan.



You can also click on the camera icon  to take a picture.

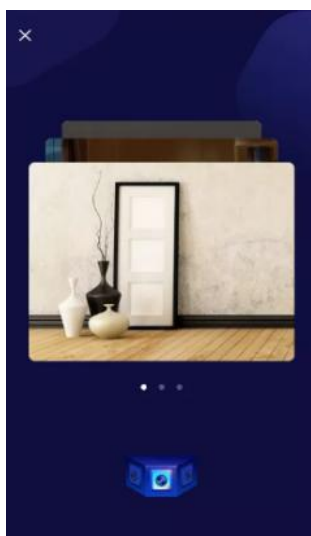

After you click start work, the real-time orientation page will open. In this page you can decide if perform a real-time orientation or not. Remember to correctly set up the RTK before using this function. If real-time orientation is selected, will be needed to choose the target projection system.

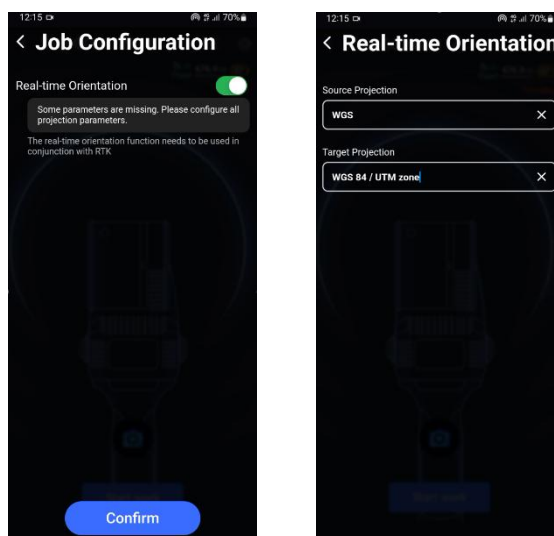

### Device Status-Connection failed

If the device connection fails, please recheck the device connection status and troubleshoot one by one:

1. Check whether the Bluetooth or the hotspot are turned on.
2. Check X200<sup>GO</sup>/ X120<sup>GO</sup> LED status.
3. Exit the work interface, return to the home page, and check whether there is a green cursor in the upper right corner of the connected device icon.
4. Try to completely close the GOapp, clear the background of GOapp, re-enter GOapp and try to connect to the X200<sup>GO</sup>/ X120<sup>GO</sup> device again.

If the connection fails when you re-enter the equipment interface after the above operation, please contact your local dealer for more assistance.

### Device status-out of communication range

When GOapp is disconnected from X200<sup>GO</sup>/ X120<sup>GO</sup>, the device status will prompt "Not in communication range". It is necessary to check whether the mobile phone is connected to the device X200<sup>GO</sup>/ X120<sup>GO</sup>, or the distance between the mobile phone and the device is too far.

### Device status - Device activation failed

If a device activation failed message appears, you need to connect the controller (phone/tablet) to an internet connection and open the application. Then the application will be able to perform time synchronization.

### Parameter initializing

After clicking *Start work*, leave the scanner still to allow the laser scanner parameters to initialise for approximately one minute. Ensure that there are no moving objects in front of the scanner at this stage.

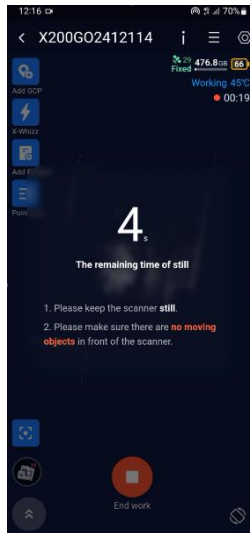

### Working page

After connecting X200<sup>GO</sup>/ X120<sup>GO</sup> through GOapp, the APP enters the standby page, and the system will automatically enter the working page and start to display the laser scanning data in real time by pressing the power button on the instrument. The interface includes:

equipment information (1), settings (2), working time, temperature, battery percentage, GNSS solution, storage (3), switching 2D or 3D display function (4), add a GCP (5), X-Whizz mode (6), add feature (7), point list (8).



Click the *End work* button to stop the acquisition.

### Working-real-time 3D scanning display

When the APP is in the standby interface, press the power key of X200<sup>GO</sup>/ X120<sup>GO</sup> device briefly to start the operation, and the page will automatically jump to the 3D scanning display interface.

### Working-View status information

In the process of X200<sup>GO</sup>/ X120<sup>GO</sup> operation, click the "Equipment Information" button at the upper right corner of the working interface to view the current basic status information, motor status information and error status information.



### Add GCP

Once you have moved on to a control point, for example, indicated by a target, you must centre the centre of the target via the cross in the base of the instrument.

At this point, clicking on the *Add GCP* icon will save the point as a GCP, you can also rename the point. In addition to the message of a successful acquisition, the new ground control point will be visible along the motion track by the presence of a yellow square, one for each point acquired.

### Add feature: geotag

Click on the add feature to take an image and save it as a geotag. You can give a name to the picture you save. After clicking confirm, the picture is saved. The camera that takes the picture is the top camera, so point the desired object with that camera (left lens).

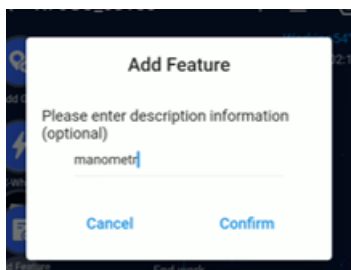

### X-Whizz mode

To activate X-Whizz mode, stop at a point and press the relevant button. An 80-second countdown will start. In this screen you can either save the image for colouring or terminate the static scan before the end of the countdown.



### Point list

The point list button opens a list showing the order of saved points (gcp, geotags) and allows their names to be changed.

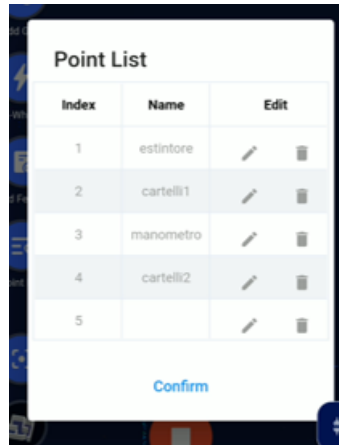

## 4.5 Settings

Click the "Settings" button in the upper right corner of the working interface to enter the setting interface. Click [Regular Settings](#) to enter the setting interface, where you can set the device name, set RTK corrections, camera parameters, Wi-fi settings, can format the internal memory and can change the point cloud visualization in real-time.

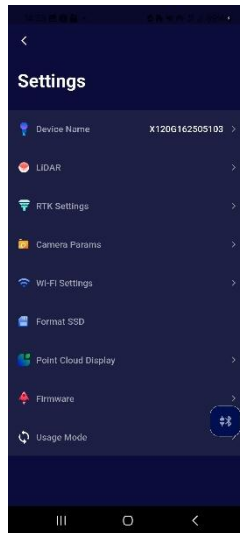

### Modify device name

Click on the Device name, enter the content to be modified in the pop-up "Modify Device Name" dialogue box, and click "Confirm" to modify the device name.

### LiDAR

With this button is possible to choose which echo save. For hand mode is suggested to use the strongest. For drone acquisition is possible to choose one of the other echoes solutions or is possible to collect all the echoes together. Double echoes for X120GOv2 and triple echoes for X200GO.

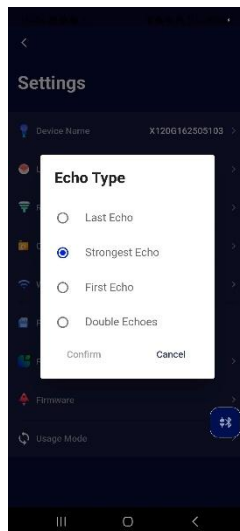

### RTK settings

On this page, you can configure the RTK settings to get corrections.

You need first to put in a SIM card which does not have a username and password in the tablet.

Second, insert the correction provider you will use in the *Connect Server*. Click on the triangle to open the list and with the plus button add the settings.

Finally, enter your account credentials and select the mount point.

By clicking on the parenthesis on the upper right corner you can check if you are receiving corrections.

Is also possible to check the GNSS status on the stand-by page.

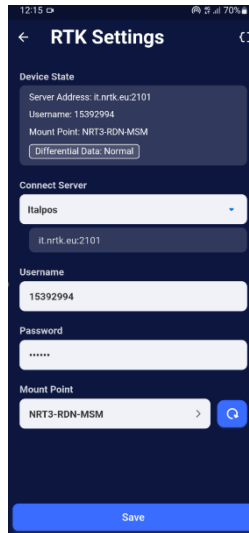

### Camera parameters

You can switch on/off the cameras, and you can change the frequency to avoid flickering in the images. Switch between 50 Hz and 60 Hz, depending on the type of lights are present in the environment. Usually LED lights can create wrong shadows, so take an image before the data acquisition and change the frequency if you notice anomalies.

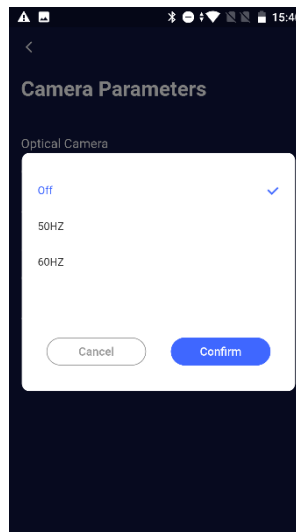

### Format SSD

Click here if you want to format the SSD of the scanner.

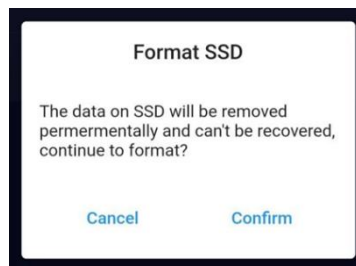

## Point Cloud Display

You can choose if visual a global preview of the point cloud in the app. Global preview may slow down the performances of your tablet.

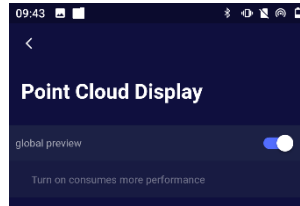

## 4.6 Firmware

Firmware update will optimize the performance of firmware or device drivers, as well as the performance of processors or other device hardware. Firmware upgrade can also fix the problems found in the old version. On the home screen, the arrow icon indicates the presence of a new firmware download. If white, there are no updates.

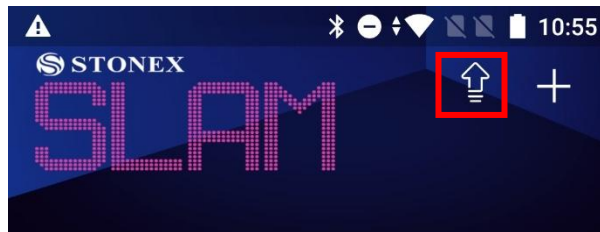

### Automatic firmware upgrade reminder

Every time you open the application to log in, the application will automatically detect the latest firmware version and the local current firmware version. If the latest firmware file is not downloaded locally, you will be reminded to download the latest firmware in the pop-up window on the home page, so that you can directly update the firmware after connecting the device. In addition, the arrow icon will turn red, signalling the presence of firmware to be updated.

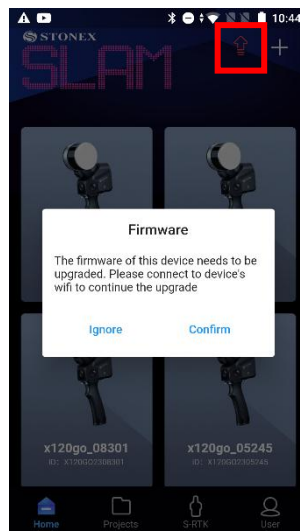

Click on the red arrow to check the firmware version to be downloaded.

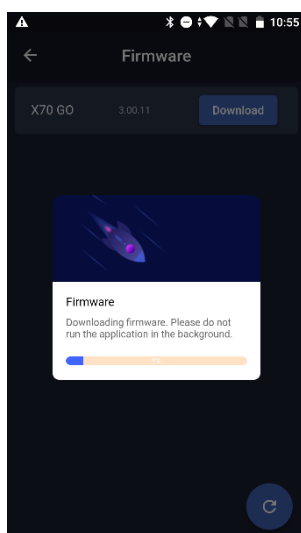

To make sure you have the latest Firmware version, open the application, before connecting to the scanner's wi-fi. Otherwise, the following message will appear.

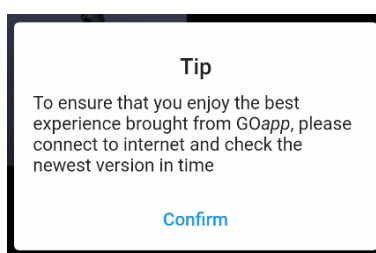

### Latest firmware download

After the firmware of the homepage pop-up window is upgraded, click OK, which will jump to the firmware download window. Click Download to start downloading. Currently, don't operate your mobile phone, wait for the download to complete, and then click OK to exit the firmware upgrade window.

### Firmware upgrade process

When the pop-up window on the home page prompts to download firmware, the firmware package will be downloaded locally.

1. When opening the app, log in to the account, click "Download the latest firmware" in the pop-up window to upgrade the firmware, and close the download page after the download is completed.
2. Turn on the X200<sup>GO</sup>/ X120<sup>GO</sup> device, connect the device Wi-Fi, click "Home" to enter the device details, click the "Settings" button in the upper right corner of the page, and click "Firmware Upgrade".
3. Click "Firmware Upgrade" in the firmware upgrade interface, and then click "Update". Please wait patiently for the firmware upgrade package to be transmitted to the X200<sup>GO</sup>/ X120<sup>GO</sup> device. Do not operate the mobile phone or X200<sup>GO</sup>/ X120<sup>GO</sup> device at this time.
4. After the transmission is completed, click OK. At this time, please wait for 35s before manually restarting the equipment. After restarting the equipment, check the LED status, and control when LED status return to normal. At this time, the firmware update is successful, and the equipment can be used normally.

In case the latest firmware package is not downloaded on the home page.

1. Turn on the X200<sup>GO</sup>/ X120<sup>GO</sup> device, connect the device Wi-Fi, and click the "Home" to enter the device details, and click the "Settings" button in the upper right corner of the page.
2. When checking the firmware upgrade, you need to disconnect the Wi-Fi connection of X200<sup>GO</sup>/ X120<sup>GO</sup> device (if the device has not acquired the latest firmware version, you will be prompted to disconnect the Wi-Fi of the device and re-enter the firmware upgrade page), keep your mobile phone connected to the Internet, and click "Firmware Upgrade".
3. After the download is completed, reconnect the Wi-Fi of X200<sup>GO</sup>/ X120<sup>GO</sup> device, exit the firmware upgrade page, and click the device on the home page again to enter the device standby page.
4. Click "Settings" in the upper right corner of the standby page, enter the firmware upgrade page, click "Firmware Upgrade" and then click "Update". Please wait patiently for the firmware upgrade package to be transmitted to X200<sup>GO</sup>/ X120<sup>GO</sup> equipment. Please do not operate your mobile phone or X200<sup>GO</sup>/ X120<sup>GO</sup> equipment at this time.
5. After the transmission is completed, click OK. At this time, please wait for 35s before manually restarting the equipment. After restarting the equipment, check the LED status, and control when LED status return to normal. At this time, the firmware update is successful, and the equipment can be used normally.

## 5. Data collection

### Device Power On

Long press the scanner power button for 3 seconds.

Wait until:

- System indicator [Blue light is always on].
- Status indicator [Green light is always on].

At this point, the device starts successfully and is in standby mode and keep the scanner on a flat and stable surface.

### Start collection

The scanner needs to be calibrated before starting data collection and should be placed at a distance of greater than 40 centimeters from the object to be measured and not too far away. The calibration phase is lead by the count down in the application and also a beep will be emitted when the system is ready to start. The scanner should not be held in the hand while calibrating but must be placed on a fixed surface such as a secure floor or tabletop.

To start the acquisition, short press the start button on the scanner, the status indicator will start to fast flashing green, at this time the device is being calibrated. Wait few seconds (cell phone APP will show a countdown to read the seconds). After the initialization, the status indicator will start flashing slowly green and can start data acquisition.

### GCP collection

When you need to collect control points, please first align the cross center of the device base to the control point, then press the control point collection button, and after hearing a beep, the control point is collected successfully.

If you are using the app you can click on Add GCP to save it and enter a name to the point.

After collecting the GCP you can continue to scan normally.

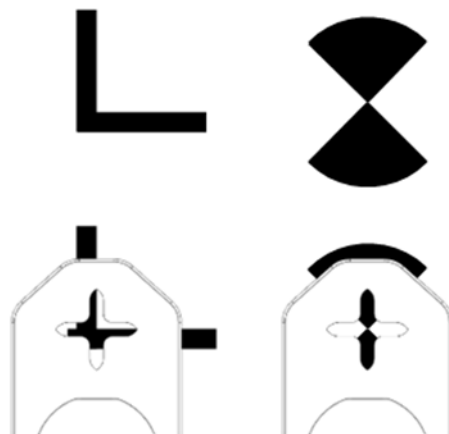

### Stop collection

Short press the scanner ON/OFF button to end data acquisition or the button on the app. The status indicator will flash as long as it is saving the cloud in real-time. When saving is complete, the LED will turn steady green and a beep will sound. In the standby state, the laser head stops rotating.

### Real-time mapping

If you need to get the results of " Real-time Mapping", please wait for the equipment to finish the " Real-time Mapping process" before shutting down the equipment.

The X200<sup>GO</sup>/ X120<sup>GO</sup> will create the map and also apply the texture in real-time processing. Will also apply orientation in real-time if real-time orientation is selected.

Wait about 1/25 of the acquisition time to get the real-time point cloud saved in the device memory before turning off the scanner. If orientation is selected, the waiting time will be longer.

Scanning time	Waiting time for real time point cloud and orientation
5 minutes	20 seconds
10 minutes	40 seconds
15 minutes	1 minute and 20 seconds
20 minutes	2 minutes
25 minutes	2 minutes and 30 seconds

### Device shutdown

Press and hold the scanner ON/OFF button to turn off the device and wait until the system indicator and status indicator are all off.

### Data download

After data collection, turn off the scanner, connect the X200<sup>GO</sup>/ X120<sup>GO</sup> to the PC with the data cable, find the folder named "SN\_XXXXX" and copy it on your PC. The system will automatically generate this folder every time the data collection is completed, and the order of data collection can be recognized according to the number at the end of the folder.

## 5.1 Data collections instructions

### Indoor Environment

If it is an indoor environment, multi-path locations should be selected as far as possible as the starting and ending points of data collection. After the site survey, plan the closed route of the survey area.

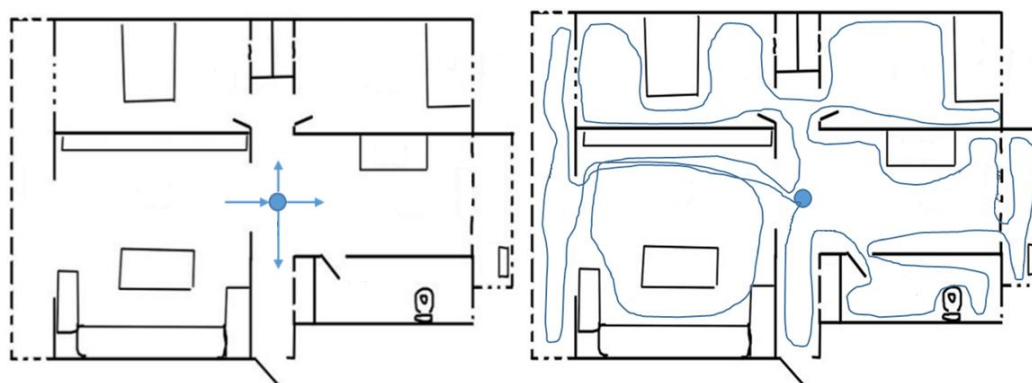

### Outdoor Environment

If it's an outdoor environment, besides finding multi-path locations and planning closed routes, it is also necessary

to ensure that the measured object is within the effective measurement range of the scanner (because of the different reflectivity of ground objects, the distance is also different).



Notice: A multipath location refers to a location that can be reached from multiple directions.

### Closed routes

- 1 The slender closed route is similar to **U-Shaped**, can barely meet the accuracy requirements. If conditions permit, users are advised not to choose this route.
- 2 The trajectory is similar to **O-shaped**, there is no redundant closed-loop, and the accuracy of data calculation is good, which is one of the most basic requirements for route selection.
- 3 **Multi O-route**: the whole track is similar to O-shaped, with many closed circles, and the data solution accuracy is the best. It is composed of many closed O-shaped routes, which greatly improves the data solution accuracy and is the best route planning.

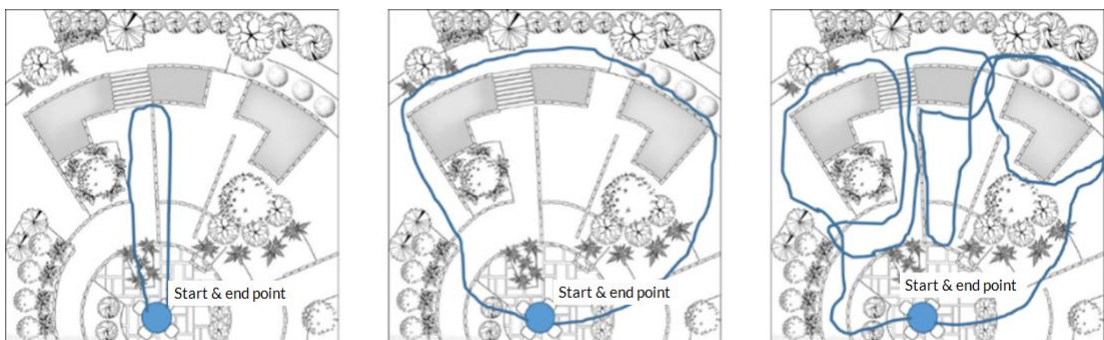

### Typical surroundings data collection considerations

X200<sup>GO</sup>/ X120<sup>GO</sup> scanner can acquire point cloud data in the range of 360×270, and the point density decreases with the increase of measurement distance. In the process of data acquisition, the device should be stable and avoid violent shaking, and non-measurement objects such as pedestrians and vehicles should be prevented from blocking the front of the device for a long time, to ensure the integrity of data acquisition.

### Precaution when passing through the door

When the hand-held scanner passes through the indoor door, it is recommended to pass slowly sideways to ensure that the scanner is relatively stable, and the door is open as much as possible. If the door is closed, when approaching the door, you need to turn the scanner back to the door and open the door with the other hand. During the process of passing through the door, you should fully consider the scanning field of vision and scan the scenes outside the door as much as possible in the room. When closing the door, try to avoid the scanner scanning the moving door as much as possible, to prevent data calculation errors.

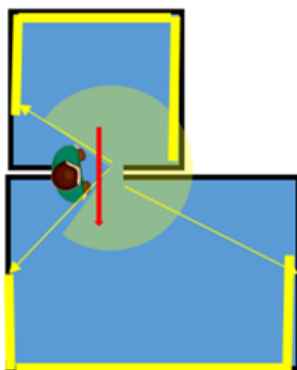

### Attention when turning corners

When the hand-held scanner passes through the corner, it is recommended to avoid too fast corners, and the way of the corner should be considered in route planning. Get as many point cloud data at the same position before and after the corner as possible to improve the accuracy of data calculation.

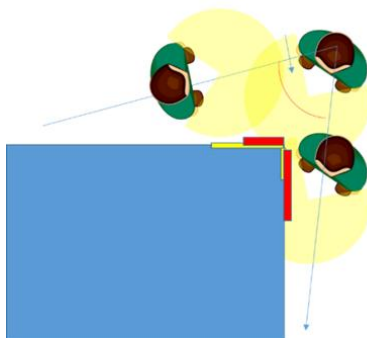

### Precautions for large-scale data acquisition

When the scanner is used to collect large-scale data, the whole survey area should be divided to facilitate the data calculation efficiency, improve the calculation accuracy and facilitate the survey area management. Divide the larger survey area into several small survey areas. It is suggested that the planned data collection time of each survey area should be 25-30 minutes, and the overlapping range of survey areas should be at least 30%.

### Suggestions for scanning long corridors (Tunnels)

Generally, the data obtained in areas with rich features and textures will have good calculation results. To ensure the calculation accuracy, it is suggested to point the scanner more to ground. In addition, during data acquisition,

attention should be paid to the incident angle of the laser, and data acquisition should be done in the middle of the corridor or tunnel as far as possible, and meaningless in-situ rotation should not be carried out, to avoid the sudden decrease of the incident angle caused by object occlusion and errors in data calculation. It is also possible to insert some box-shaped features to improve accuracy.

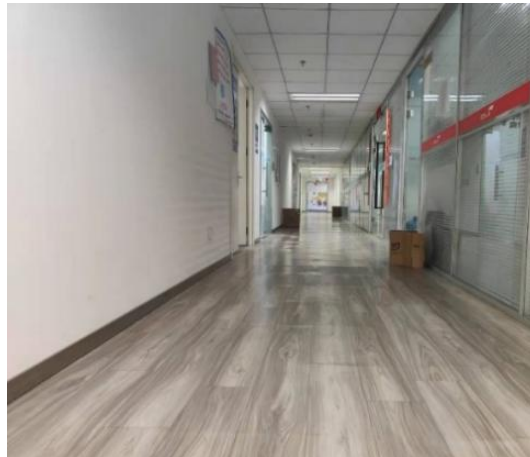

## 5.2 X-Whizz collection

With X200<sup>GO</sup>/ X120<sup>GO</sup> it is possible to collect data in static mode, called X-WHIZZ.

X-WHIZZ will let you collect data in a static mode, along the slam scanning. This way in the final result you will be able to have more precise spots, with an improved colorization.

### Data collection

To perform the acquisition with the static mode, you need to stop and keep the scanner stationary for at least 10 seconds; we suggest waiting for a time between 1 minute and 2 minutes.

When you arrive at the position you want to perform the static acquisition, put the scanner on a flat surface or use the special monopod from STONEX. To obtain the best results with the X-WHIZZ, we recommend placing the scanner at 10 meters from the desired object

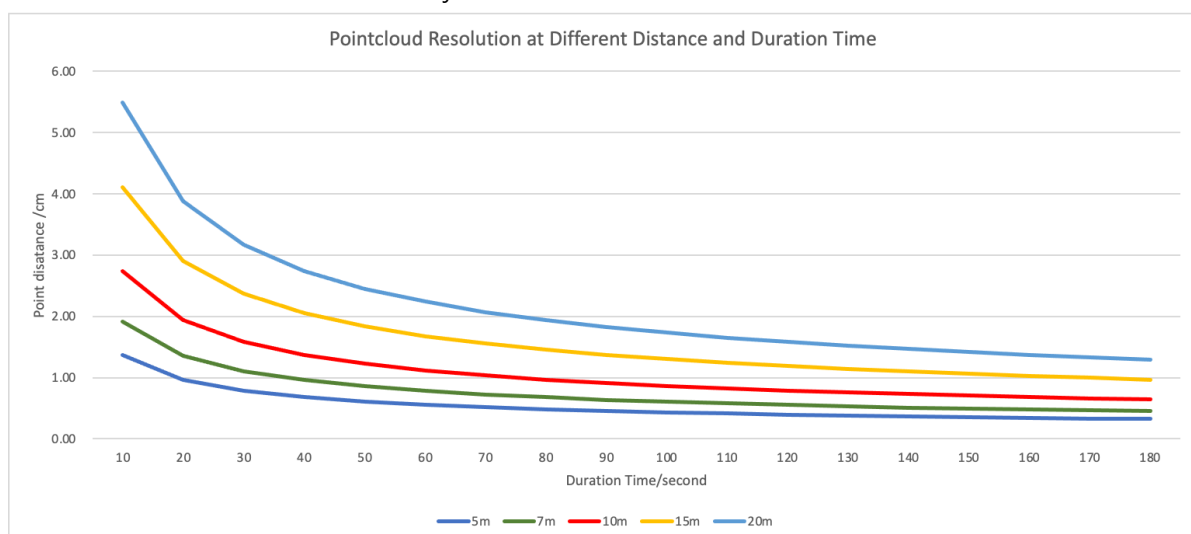

Point the camera facing the object that you want to scan.

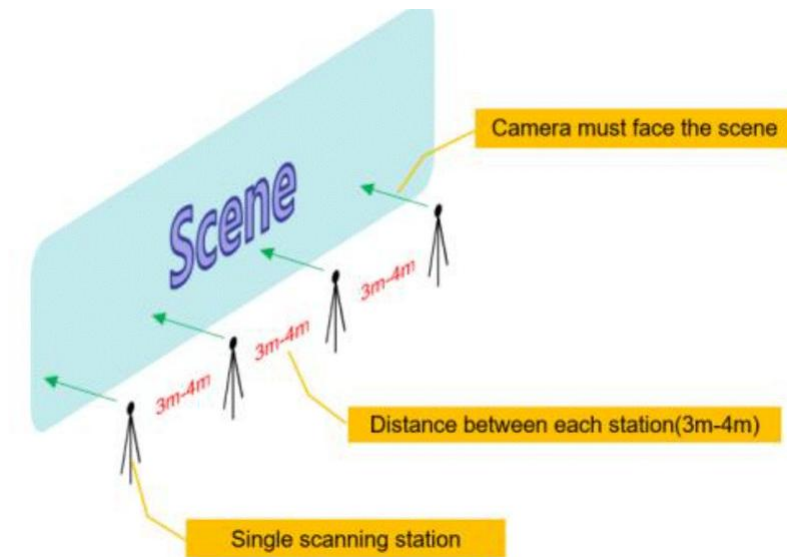

To collect the static, use the application and click the X-WHIZZ button, a countdown will start. Depending on the density of the points it's recommended to stay in the static position for 40 to 80 second. You can exit this mode anytime you want. During the static scanning the operator can remain behind the scanner, is important that nothing pass in front of it. To apply the colour to the static point cloud, you need to choose the image that will be used for the colorization. To do so, press the corresponding button (Frame Selection) in the application to save the frame.



Exit the X-WHIZZ mode. Now it's possible to continue the slam scanning operation or move to another static position and repeat the X-WHIZZ collection procedure. Between two acquisitions it's recommended to have a minimum distance of 3-4 meters.

For data processing in the GOpot software select the platform "Static" to process only the X-WHIZZ acquisition, or "Static+Dynamic" to process both X-WHIZZ and SLAM acquisitions.

### 5.3 RTK data acquisition

The following rules should be followed for the correct use of the RTK:

1. Before starting a scan, check the signal quality. Remain in Fixed solution for at least one minute before starting a scan with the instrument. Only data in Fixed solution will be used for orientation.

2. Acquire for at least 50% of the scan duration in Fixed solution. Check the signal status during acquisition.
3. In the case of mixed (indoor-outdoor) acquisition, ensure that at least 50% of the scan is performed outdoors with good signal coverage in Fixed solution. Acquire data outdoors both before entering the area without signal and afterwards, to help the software to better reconstruct the cloud and perform the orientation correctly.
4. If you acquire for a long time in a zone without a good signal (solution is not Fixed), when you return outdoors, return to the RTK screen, and check the connection status. If it does not immediately return to the Fixed solution, click on settings, and resave the mount point to resume communication.

## 5.4 Drone data collection

### Install UAV mount:

- 1) Remove X200<sup>GO</sup>/ X120<sup>GO</sup> handle, and connect the UAV mount, removing the cover.
- 2) Anchor the scanner to the drone using the payload connector



### Planning of the flight:

For the planning of the flight X200<sup>GO</sup>/ X120<sup>GO</sup> use the parameters in the following image

Photo Size	
<i>Width</i>	<i>Height</i>
1000px	1000px
Sensor Size	
<i>Width</i>	<i>Height</i>
10.0mm	10.0mm
Focal Length	
5.0mm	
Minimum Interval Between Photos	
1.0s	

### Flight execution:

Turn on the drone controller and the drone. Once the drone is connected to the controller set the RTK corrections using the drone interface.

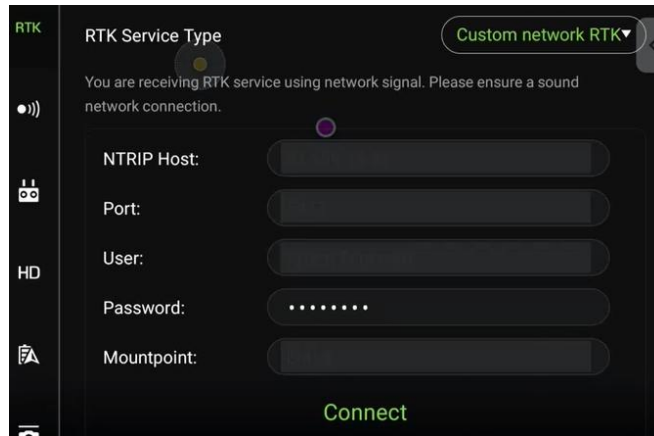

Then turn on the scanner and connect it using GOapp. In the app enter the scanning page and go in the settings.



Select usage mode and choose "Payload Mode", then in the settings click on LiDAR to select the necessary returns. Go back to the scanner page, when able to flight, press "Start work" button, and deselect the Real-Time Orientation (the scanner is using the RTK drone data). Wait until the parameter initialization, make sure there are no moving objects in front of the scanner. Now you can start the flight.

During the flight, especially far from the take off points, the scanner may disconnect from the controller, and the GOapp preview may are not available, but data will still be recorded correctly.

When the flight is over land the drone and reconnect the scanner to stop the scan, wait for the processing of data. Turn off the scanner and the drone.

For data processing in the GOpost software select the platform "UAV mount".

## 5.5 Data Processing

Post-processing of the X200<sup>GO</sup>/ X120<sup>GO</sup> data is done via the GOpost software. This is used if you want to reprocess the data and if you want to colour the cloud. For more information on this, please refer to the GOpost manual.

## 6. Radio kit

- 1) Connect the radio to the scanner using the Lemo connector (blue → scanner)



- 2) Turn on the scanner and the radio
- 3) Set the radio parameters

Radio Parameters
Channel Tx/Rx Freq. 438.125 MHz
Data Protocol: TrimTalk 450S
Radio Link Rate: 9600-25 kHz
Radio Mode: Rx Only
Serial Baud: 115200
Data Link: Uart

These allow a correct communication with the base station and data transmission with the scanner.

- 4) Set the base communication accordingly

Base Communication
<i>Internal Radio</i>
Channel: 1:438.12500
Frequency: 438.12500
Protocol: TrimTalk 450S (T)

- 5) Connect the scanner to GOapp  
The number of visible satellites will appear in a fixed solution.

## 7. Software license activation request

GOpost can work with the dongle license available in the X200<sup>GO</sup>/ X120<sup>GO</sup> box.

If needed is also possible activate a software license key.

After opening GOpost, click in the upper right corner on the button *Software licensing*.

In a new window the license screen will open.

Contact your local dealer in order to request the license activation. You will need to provide the UUID and the serial number of the instrument.

As soon as you receive the .fmpkt file, import it into GOpost via the license management page.

License

SLAM Serial ID

Device UUID  Copy

Authorization Status None

Date of Expiry None

Import Authorization File

Now the license is active.

## 8. Technical data

### 8.1 Bundle components

N	PART NAME	QUANTITY
1	Scanner	1
2	Handle battery	1
3	Scanner base bracket for GCP	1
4	Type-c cable	1
5	Battery chargers EU/US	1
6	USB License key for GOpod	1
7	RTK bracket + antenna	1

## 9. Appendix

### 9.1 X200<sup>GO</sup> technical features

#### LIDAR

Sensor model	Hesai XT32M2X
Max Range	300 m
Min Range	0.5 m
Return number	3
Scanning Point Frequency	640.000 pts/s
Field Of View	360° x 290°
Laser class	Class 1 eye-safe per IEC/EN 60825-1:2014
Channels	32
Wavelength	905 nm

#### GNSS RECEIVER

Satellite signals tracked	GPS L1 C/A/L2P(y)/L2C/L5 GLONASS L1/L2 Galileo E1/E5A/E5B BDS B1I/B2I/B3I QZSS L1/L2/L5
DPGS (RMS)	Horizontal 0.4 m + 1 ppm Vertical 0.8 m + 1 ppm
RTK (RMS)	Horizontal 0.8 cm + 1 ppm Vertical 1.5 cm + 1 ppm
Speed accuracy (RMS)	0.03 m/s

## COLOR CAMERA

Pixel	24 Mpx (2 cameras 12 Mpx each)
Diagonal FOV	210°
Focal length	1.26 mm
Resolution	4000 x 3000 pixel
Sensor size	1 / 2.3 inch
Pixel size	1.55 µm

## SYSTEM

Relative accuracy	Up to 6 mm <sup>1</sup>
Global accuracy	Up to 2 cm <sup>1</sup> 5 cm on UAV platform <sup>1</sup>
Control point support	Ground and wall
Operative mode	SLAM and X-Whizz modes, Real-time visualization, colouring and orientation
Data storage	512 GB SSD
Communication	Wi-Fi, Bluetooth, USB type-C, Lemo connector
Post-processing	Real-time processing, Post-processing with GOpost <sup>2</sup>

## DATA TRANSMISSION

Frequency range	BT: 2402 ~2480 MHz Wi-Fi 2.4G: 2412 ~ 2472 MHz Wi-Fi 5.2G: 5180 ~ 5240 MHz Wi-Fi 5.8G: 5745 ~ 5825 MHz GPS L1-C/A, L1C: 1575.42 MHz GPS L2C: 1227.60 MHz GPS L5: 1176.45 MHz BeiDou B1I, B1C: 1561.098 MHz Galileo E1: 1575.42 MHz Galileo E5b: 1201.5 MHz Galileo E5a: 1176.5 MHz Galileo E6: 1278.75 MHz Glonass G1: 1602.5625 MHz Glonass G2: 1242.4375 MHz
Max output power	BDR+EDR: 7.83dBm Max BLE: 7.39dBm Max Wi-Fi 2.4G: 17.14dBm Max Wi-Fi 5.2G: 17.08dBm Max Wi-Fi 5.8G: 12.94dBm Max
Standard	EN 300 328 V2.2.2 EN 301 893 V2.1.1 EN 301 893 V2.1.1

	EN 303 413 V1.2.1
Modulation	BT: GFSK, $\pi/4$ -DGPSK, 8-DPSK
	BLE: GFSK
	Wi-Fi 2.4G: DSSS, OFDM
	Wi-Fi 5.2G: OFDM
	Wi-Fi 5.8G: BPSK

#### ELECTRICAL SPECIFICATION

Power consumption	26 W
System supply voltage	20 V
Operating time	1.2 h (single battery)
External power	USB type-c
Battery input voltage	5-20 V
Battery output voltage	10.8 V
Battery capacity	3000 mAh

#### PHYSICAL SPECIFICATION

Weight	1.4 kg (Without battery)
	1.9 kg (With battery)
Size	403.6 mm x 173.8 mm x 170 mm
Operating temperature	-20°C to +50°C (-4°F to 122°F)
Operating humidity	<95%
Waterproof/Dustproof	IP54

#### PLATFORM/EXTENSION

Backpack	✓
RTK module	Integrated
360° camera	Integrated
	Insta X360 X4/X5
Vehicle mount	✓
UAV	DJI M300/350
Radio Modem	Stonex SR02

<sup>1</sup> Environment dependent

<sup>2</sup> Any CPU, any NVIDIA GPU

## 9.2 X120<sup>GO</sup> technical features

### LIDAR

Sensor model	Hesai XT16   XT32
Max Range	120 m
Min Range	0.05 m
Return number	2

Scanning Point Frequency	320.000   640.000 pts/s
Field Of View	360° x 290°
Laser class	Class 1 eye-safe per IEC/EN 60825-1:2014
Channels	16   32
Wavelength	905 nm

## GNSS RECEIVER

Satellite signals tracked	GPS L1 C/A/L2P(Y)/ L2C/L5 GLONASS L1/L2 Galileo E1/E5a/E5b BDS B1I/B2I/B3I QZSS L1/L2/L5
DPGS (RMS)	Horizontal 0.4 m + 1 ppm Vertical 0.8 m + 1 ppm
RTK (RMS)	Horizontal 0.8 cm + 1 ppm Vertical 1.5 cm + 1 ppm
Speed accuracy (RMS)	0.03 m/s

## COLOR CAMERA

Pixel	24 Mpx (2 cameras 12 Mpx each)
Diagonal FOV	210°
Focal length	1.26 mm
Resolution	4000 x 3000 pixel
Sensor size	1 / 2.3 inch
Pixel size	1.55 µm

## SYSTEM

Relative accuracy	Up to 6 mm <sup>1</sup>
Global accuracy	Up to 2 cm <sup>1</sup> 5 cm on UAV platform <sup>1</sup>
Control point support	Ground and wall
Operative mode	SLAM and X-Whizz modes, Real-time visualization (colored and oriented)
Data storage	512 GB SSD
Communication	Wi-Fi, Bluetooth, USB type-C, Lemo connector
Post-processing	Real-time processing, Post-processing with GOpost <sup>2</sup>

## ELECTRICAL SPECIFICATION

Power consumption	26 W
-------------------	------

System supply voltage	20 V
Operating time	1.2 h (single battery)
External power	USB type-c
Battery input voltage	5-20 V
Battery output voltage	10.8 V
Battery capacity	3000 mAh

#### PHYSICAL SPECIFICATION

Weight	1.6 kg (Without battery)
	2.1 kg (With battery)
Size	404 mm x 170mm x 188mm
Operating temperature	-20°C to +50°C (-4°F to 122°F)
Operating humidity	<95%
Waterproof/Dustproof	IP54

#### PLATFORM/EXTENSION

Backpack	✓
RTK module	Integrated
360° camera	Integrated
	Insta X360 X4/X5
Vehicle mount	✓
UAV	DJI M300/350
Radio Modem	Stonex SRO2

<sup>1</sup> Environment dependent

<sup>2</sup> Any CPU, any NVIDIA GPU



STONEX® SRL

Viale dell'industria, 53 | 20037 - Paderno Dugnano (MI) | Italy

Tel : + 390278619201 | Fax :+ 390278610299

[www.stonex.com](http://www.stonex.com) | [info@stonex.com](mailto:info@stonex.com)